

Acrobat

user manual

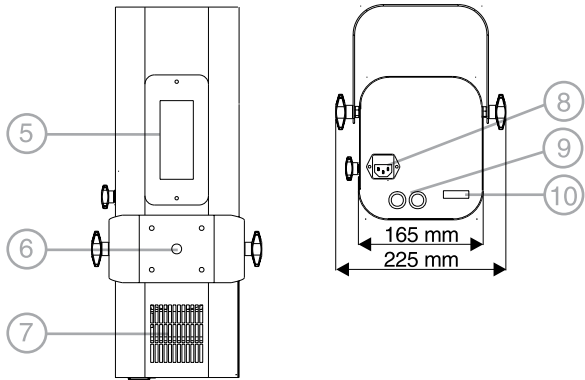

- 1 mounting bracket
- 2 swivel locks
- 3 focus adjustment
- 4 effects cover
- 5 lamp access
- 6 13 mm clamp hole
- 7 air vent
- 8 AC input & main fuse
- 9 data sockets
- 10 DIP-switch

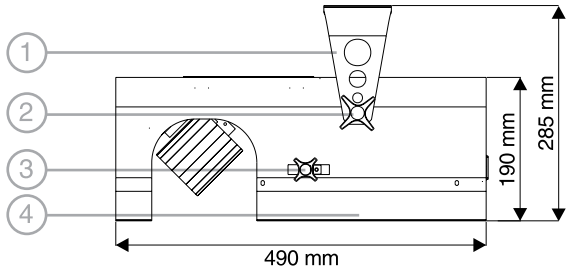

©1999 - 2001 Martin Professional A/S, Denmark.

All rights reserved. No part of this manual may be reproduced, in any form or by any means, without permission in writing from Martin Professional A/S, Denmark.

Printed in Denmark.

P/N 35000039, Rev. H

Introduction	4
Acrobat safety information	4
Unpacking	5
Lamp replacement	6
AC power connection	7
Installation	8
Data connection	10
Recommended cable	10
Connections	10
Stand-alone operation	12
Single unit operation	12
Master / slave operation	12
Stand-alone settings	13
MC-1 operation	14
MC-1 settings	14
DMX operation	15
DMX modes	15
DMX address	15
1-channel DMX operation	17
6/7-channel DMX operation	17
Basic service	18
Troubleshooting	19
DMX protocol	21
Specifications	22

INTRODUCTION

Thank you for selecting the Martin Acrobat. The Acrobat is an automated disco lighting fixture that provides strobe effects, continuous electronic dimming, 18 color/gobo effects, a revolving mirror drum with variable swivel angle, adjustable focus, and multiple control options.

ACROBAT SAFETY INFORMATION

Warning! This product is not for household use. It presents risks of lethal or severe injury due to fire and heat, electric shock, and falls.

Read this manual before powering or installing the fixture, follow the safety precautions listed below and observe all warnings in this manual and printed on the fixture. If you have questions about how to operate the fixture safely, please contact a Martin distributor for assistance.

To protect yourself and others from electric shock

- Disconnect the fixture from AC power before removing or installing the lamp, fuses, or any part, and when not in use.
- Always ground (earth) the fixture electrically.
- Use only a source of AC power that complies with local building and electrical codes and has both overload and ground-fault protection.
- Do not expose the fixture to rain or moisture.
- Refer all service to a qualified technician.
- Never operate the fixture with missing or damaged lenses and/or covers.

LAMP REPLACEMENT

2

The Acrobat comes from the factory with a Philips 500 hour lamp installed. This is a 24V, 250W ELC halogen lamp. A high-output 50 hour lamp from Osram is also available. *Installing any other lamp may damage the fixture!*

Lamp life can be extended beyond the stated average hours by reducing the lamp voltage slightly using DIP-switch pin 12. Set pin 12 to ON for longer lamp life, or OFF for maximum brightness.

Allow the lamp to cool for at least 5 minutes before packing and moving the fixture. To avoid possible damage, remove the lamp when shipping the fixture.

Warning! *Always disconnect the fixture from AC power and allow it to cool for 5 minutes before installing the lamp.*

To install a lamp in the Acrobat

- 1 Disconnect the fixture from AC power. If replacing a lamp, allow it to cool for 5 minutes before removing the lamp access cover. The lamp cools faster with the cover in place.
- 2 Remove both screws from the lamp access cover and lift the cover off.
- 3 If replacing a lamp, grasp the old lamp by the reflector and pull it out of the holder. Then pull the socket off the lamp. Do not pull the wires.
- 4 Push the socket fully onto the pins of the new lamp.
- 5 Gently push the lamp into the holder until it snaps into place.
- 6 Replace the lamp access cover and screws.

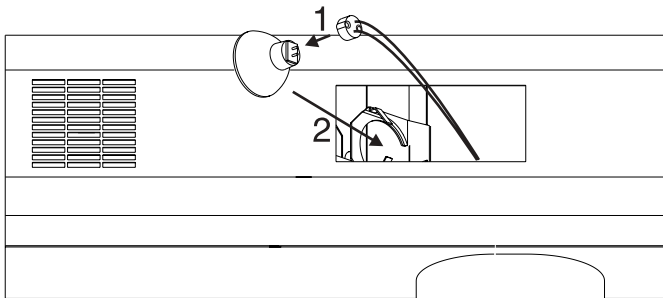

AC POWER CONNECTION

The Acrobat's operating voltage is printed on the serial number label near the AC input. Verify that the operating voltage closely matches the AC supply voltage before applying power. Contact your Martin dealer if the operating voltage differs from the supply voltage by more than five percent.

To install a plug on the mains lead

The fixture's mains lead may require a grounding-type cord cap that fits your power distribution cable or outlet. Consult a qualified electrician if you have any doubts about proper installation.

Warning! *For protection from dangerous electric shock, the fixture must be grounded (earthed). The AC mains supply shall have overload and ground-fault protection.*

Important! *Verify that the feed cables are undamaged and rated for the current requirements of all connected devices before use.*

- Following the cord cap manufacturer's instructions, connect the yellow and green wire to ground (earth), the brown wire to live, and the blue wire to neutral. The table below shows some pin identification schemes.

Wire	Pin	Marking	Screw color
brown	live	"L"	yellow or brass
blue	neutral	"N"	silver
yellow/green	ground		green

INSTALLATION

4

The Acrobat can be permanently installed or hung with a clamp (not included), or it can be placed on the floor as described below. For maximum lamp life, do not place the fixture directly on or beside a speaker cabinet or other source of strong vibrations.

Once the Acrobat is installed and connected, the focus may be adjusted by loosening and sliding the focus adjustment knob.

Warning! *Block access below the work area before proceeding.*

Warning! *Always use a secure means of secondary attachment.*

To install the mounting bracket

- Install the mounting bracket on the chassis as shown. Place the washers on the stud before the bracket.

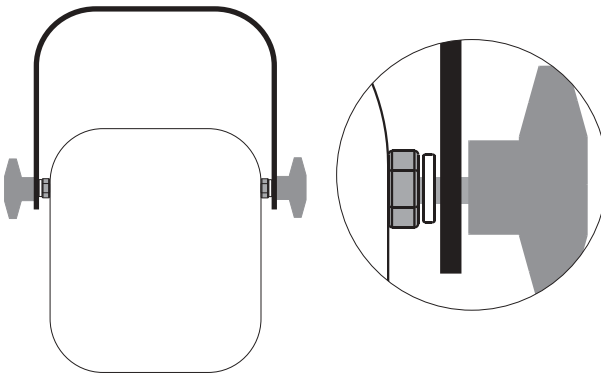

To install or hang the Acrobat

- 1 Verify that the structure can support at least 10 times the weight of all installed fixtures, clamps, cables, auxiliary equipment, etc.
- 2 If hanging the fixture with a rigging clamp, verify that the clamp is undamaged and is designed for the fixture's weight. Bolt the clamp securely to the bracket with a grade 8.8 (minimum) M12 bolt and lock nut, or as

recommended by the clamp manufacturer, through the clamp hole in the mounting bracket.

- 3 If permanently installing the fixture, verify that the hardware (not included) and mounting surface can bear at least 10 times the fixture's weight. The four 6 mm holes and the clamp hole in the mounting bracket may be used for attachment.
- 4 Working from a stable platform, clamp or fasten the fixture to the structure.
- 5 Install a safety cable that can hold at least 10 times the weight of the fixture through/over the support and mounting bracket as shown.
- 6 Loosen the swivel locks, tilt the fixture to the desired angle, and retighten.
- 7 Verify that the fixture is at least 0.3 meters (12 in.) from the surface to be illuminated and at least 0.1 meters (4 in.) from any combustible materials. Verify that the clearance around the air vents is at least 0.1 meters (4 in.).

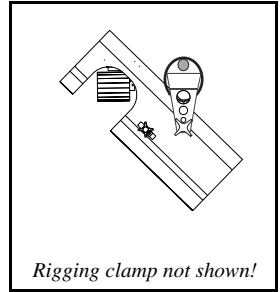

To use the bracket as a floor stand

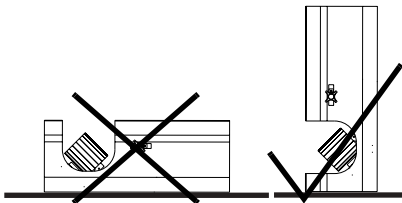

The Acrobat may be placed on the floor by standing it squarely on the drum end or with the support of the mounting bracket. *Never lay the fixture flat on its back!*

- 1 Install the mounting bracket as described above.
- 2 Set the fixture flat on its drum end or in one of the positions shown below. Adjust the mounting bracket and tighten both swivel locks.
- 3 Verify (1) that the fixture is stable, (2) that the fixture is at least 0.3 meters (12 in.) from the surface to be illuminated and at least 0.1 meters (4 in.) from any combustible materials, and (3) that the clearance around the air vents is at least 0.1 meters (4 in.).

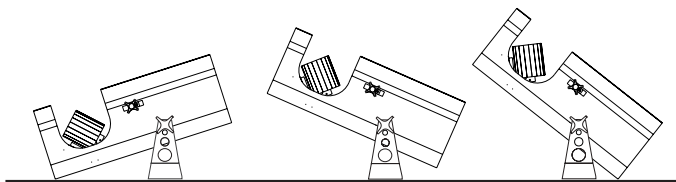

DATA CONNECTION

5

This section describes how to connect fixtures to a controller.

RECOMMENDED CABLE

A reliable data connection begins with the right cable. Standard microphone cable cannot transmit DMX data reliably over long runs. For best results, use cable specifically designed for RS-485 applications. Your Martin dealer can supply high quality cable in various lengths.

CONNECTIONS

The Acrobat's XLR data sockets are wired with pin 1 to ground, pin 2 to signal - (cold), and pin 3 to signal + (hot). This is the standard pin assignment for DMX devices.

One or more adaptor cables may be required to connect the Acrobat to the controller and/or other lights because many devices have 5-pin connectors and others may have reversed signal polarity, that is, pin 2 hot and pin 3 cold.



5-pin to 3-pin Adaptor	
Male	Female
1	1
2	2
3	3
4	
5	
P/N 11820005	

3-pin to 5-pin Adaptor	
Male	Female
1	1
2	2
3	3
	4
	5
P/N 11820004	

3-pin to 3-pin Phase-Reversing Adaptor	
Male	Female
1	1
2	3
3	2
P/N 11820006	

To connect the data link

- 1 Connect a data cable to the controller's output. If controller has a 5-pin output, use a 5-pin male to 3-pin female adaptor cable (P/N 11820005).
- 2 Lead the data cable from the controller to the first fixture. Plug the cable into the fixture's data input.
- 3 Connect the output of the fixture closest to the controller to the input of the next fixture. If connecting two fixtures with reversed polarity on pins 2 and 3, insert a phase-reversing cable between the two fixtures.
- 4 Continue connecting fixtures output to input. Up to 32 devices may be connected on a serial link.
- 5 Terminate the link by inserting a male termination plug (P/N 91613017) into the data output of the last fixture. A termination plug is simply an XLR connector with a 120 ohm, 0.25 W resistor soldered across pins 2 and 3.

Male Termination Plug	Female Termination Plug
Male XLR 1 2 3  120	Female XLR 1 2 3  120
P/N 91613017	P/N 91613018

STAND-ALONE OPERATION

The Acrobat may be operated without a controller in stand-alone mode. It may be operated as a single unit or together with other Acrobats in “master/slave” configuration.

Several options are available to modify stand-alone operation. These options are selected using the DIP-switch as described below.

Important! ***The Acrobat transmits a signal when DIP-switch pins 2 and 10 are set to ON. To avoid damage to the electronics, connect no more than 1 transmitting device (master or controller) to the data link.***

SINGLE UNIT OPERATION

The fixture defaults to stand-alone mode with music trigger whenever power is applied and there is no control signal. Options for trigger type, mirror speed and movement range, and lamp intensity may be selected as described under “Stand-alone settings”.

MASTER / SLAVE OPERATION

Multiple Acrobats can be connected together, without a controller, for synchronized “master/slave” operation in which the slaves mimic the behavior of the master.

To connect units for master / slave operation

- 1 Connect the output of one Acrobat to the input of the next Acrobat.
- 2 Connect additional Acrobats output to input. Up to 32 may be connected.
- 3 Terminate the link on both ends by inserting a *female* termination plug into the data *input* of the first fixture and a *male* termination plug into the data *output* of the last fixture. (The female terminator may not be required if the first fixture is the master.) A termination plug is simply an XLR connector with a 120 ohm, 0.25 W resistor soldered across pins 2 and 3.

To set the master

Important! Set only 1 fixture as master (DIP-switch pin 2 and 10 ON).

- 1 Set DIP-switch pins 2 and 10 to ON.
- 2 Set DIP-switch pins 3, 5, 6, 7, 8, 9, and 11 to OFF.
- 3 Select options with DIP-switch pins 1, 4, and 12.



To set a slave

- 1 Set DIP-switch 10 to ON.
- 2 Set pins 1, 2, 3, 4, 5 and 11 to OFF.
- 3 Select options with DIP-switch pins 6, 7, 8, 9, and 12.

STAND-ALONE SETTINGS

DIP-switch pins 1-9 enable stand-alone options only when pin 10 is ON. When pin 10 is off, the DIP-switch selects a DMX address. *Pin 11 must be OFF for stand-alone operation.*

Pin 12 selects lamp power and works in all modes. Set it to ON for reduced lamp voltage and longer lamp life; set it to OFF for full intensity.

The DIP-switch 10 setting takes effect only after the fixture has been turned off and on.

Fixture	Option	Setting (0 = OFF, 1 = ON)										
		1	2	3	4	5	6	7	8	9	10	11
single or master	auto trigger	0	1	0					0			
	music trigger	1	1	0					0			
	slow movement		1	0	1				0			
slave	Random color/gobo			0			1					
	Use a different gobo in relation to the master.			0				1			1	0
	Rotate the mirror drum in the opposite direction to the master.			0					1			
	Swivel the mirror drum in the opposite direction to the master			0						1		

MC-1 OPERATION

All new Acrobats and older Acrobats with CPU firmware v 1.4 or higher are fully compatible with the Martin MC-1 Controller. See the MC-1 user manual for additional information.

MC-1 SETTINGS

DIP-switch pin 10 must be set to OFF to enable MC-1 mode operation. Changes to the setting take effect after the fixture has been turned off and on.

DIP-switch pins 6, 7, 8, and 9 select several control options that can be combined to achieve powerful effects quickly and easily.

Pin 12 selects lamp power and works in all modes. Set it to ON for reduced lamp voltage and longer lamp life; set it to OFF for full intensity.

Option	Setting (0 = OFF, 1 = ON)										
	1	2	3	4	5	6	7	8	9	10	11
Inverted parabolic reflector						1				0	
Use a different color/gobo.							1			0	
Rotate the mirror drum in the opposite direction (to that requested by the MC-1)								1		0	
Swivel the mirror drum in the opposite direction (to that requested by the MC-1)									1	0	

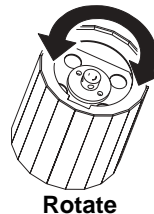
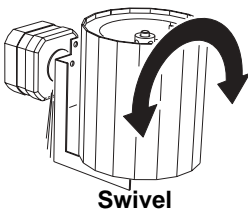

DMX OPERATION

DMX MODES

The Acrobat has 3 DMX modes to choose from: a 1-channel mode that provides control of the built-in stand-alone features, a 6-channel mode that provides position control of all effects plus speed control of the drum swivel movement, and an “extended” 7-channel mode that in addition provides speed control of the effect wheel.

To select DMX mode

- 1 **Disconnect the fixture from power. Set DIP-switch pin 10 to OFF.**
- 2 **To select 1-channel DMX mode, set DIP-switch pin 11 to ON.**
- 3 **To select 6-channel DMX mode, set DIP-switch pin 11 to OFF. The 6/7 ch. jumper is set at the factory for 6 channel mode, which is recommended for most applications.**
- 4 **To select 7-channel DMX mode, set DIP-switch pin 11 to OFF. Set the 6/7 ch. jumper for 7 channels as described on page 18.**

DMX ADDRESS

DIP-switch pins 1-9 are used to set the control address. The address, also known as the start channel, is the first channel used to receive instructions from the controller.

For independent control, each fixture must be assigned its own address and non-overlapping control channels. Two Acrobats may share the same address only if they are to respond identically: they will receive the same instructions and individual control will not be possible.

To select DMX address

- 1 **Select an address for the fixture on your controller. Look up the DIP-switch setting for the address in the DIP-switch settings table below.**
- 2 **Disconnect the fixture from power.**

3 Set pins 1 through 9 to the ON (1) or OFF (0) position as listed in the table.

Find the address in the table below. Read the settings for pins 1 - 5 to the left and read the settings for pins 6 - 9 above the address. "0" means OFF and "1" means ON. Pin 10 is always OFF for DMX operation.

DIP-Switch Setting					#9	0	0	0	0	0	0	0	0	1	1	1	1	1	1	1	1	
0 = OFF					#8	0	0	0	0	1	1	1	1	0	0	0	0	0	1	1	1	1
1 = ON					#7	0	0	1	1	0	0	1	1	0	0	1	1	0	0	1	1	1
					#6	0	1	0	1	0	1	0	1	0	1	0	1	0	1	0	1	1
#1	#2	#3	#4	#5																		
0	0	0	0	0	32	64	96	128	160	192	224	256	288	320	352	384	416	448	480			
1	0	0	0	0	1	33	65	97	129	161	193	225	257	289	321	353	385	417	449	481		
0	1	0	0	0	2	34	66	98	130	162	194	226	258	290	322	354	386	418	450	482		
1	1	0	0	0	3	35	67	99	131	163	195	227	259	291	323	355	387	419	451	483		
0	0	1	0	0	4	36	68	100	132	164	196	228	260	292	324	356	388	420	452	484		
1	0	1	0	0	5	37	69	101	133	165	197	229	261	293	325	357	389	421	453	485		
0	1	1	0	0	6	38	70	102	134	166	198	230	262	294	326	358	390	422	454	486		
1	1	1	0	0	7	39	71	103	135	167	199	231	263	295	327	359	391	423	455	487		
0	0	0	1	0	8	40	72	104	136	168	200	232	264	296	328	360	392	424	456	488		
1	0	0	1	0	9	41	73	105	137	169	201	233	265	297	329	361	393	425	457	489		
0	1	0	1	0	10	42	74	106	138	170	202	234	266	298	330	362	394	426	458	490		
1	1	0	1	0	11	43	75	107	139	171	203	235	267	299	331	363	395	427	459	491		
0	0	1	1	0	12	44	76	108	140	172	204	236	268	300	332	364	396	428	460	492		
1	0	1	1	0	13	45	77	109	141	173	205	237	269	301	333	365	397	429	461	493		
0	1	1	1	0	14	46	78	110	142	174	206	238	270	302	334	366	398	430	462	494		
1	1	1	1	0	15	47	79	111	143	175	207	239	271	303	335	367	399	431	463	495		
0	0	0	0	1	16	48	80	112	144	176	208	240	272	304	336	368	400	432	464	496		
1	0	0	0	1	17	49	81	113	145	177	209	241	273	305	337	369	401	433	465	497		
0	1	0	0	1	18	50	82	114	146	178	210	242	274	306	338	370	402	434	466	498		
1	1	0	0	1	19	51	83	115	147	179	211	243	275	307	339	371	403	435	467	499		
0	0	1	0	1	20	52	84	116	148	180	212	244	276	308	340	372	404	436	468	500		
1	0	1	0	1	21	53	85	117	149	181	213	245	277	309	341	373	405	437	469	501		
0	1	1	0	1	22	54	86	118	150	182	214	246	278	310	342	374	406	438	470	502		
1	1	1	0	1	23	55	87	119	151	183	215	247	279	311	343	375	407	439	471	503		
0	0	0	1	1	24	56	88	120	152	184	216	248	280	312	344	376	408	440	472	504		
1	0	0	1	1	25	57	89	121	153	185	217	249	281	313	345	377	409	441	473	505		
0	1	0	1	1	26	58	90	122	154	186	218	250	282	314	346	378	410	442	474	506		
1	1	0	1	1	27	59	91	123	155	187	219	251	283	315	347	379	411	443	475	507		
0	0	1	1	1	28	60	92	124	156	188	220	252	284	316	348	380	412	444	476	508		
1	0	1	1	1	29	61	93	125	157	189	221	253	285	317	349	381	413	445	477	509		
0	1	1	1	1	30	62	94	126	158	190	222	254	286	318	350	382	414	446	478	510		
1	1	1	1	1	31	63	95	127	159	191	223	255	287	319	351	383	415	447	479	511		

1-CHANNEL DMX OPERATION

The functions shown in the following table are available in 1-channel mode. When a “stand-alone” function is selected, the fixture steps through a routine using a built-in microphone to trigger the action to the beat of the music. Note that multiple fixtures cannot be synchronized in this mode.

DMX value	Percent	Function
0 - 10	0 - 4	Blackout (light off)
11 - 20	5 - 7	Open (light on)
21 - 80	8 - 31	Strobe
81 - 115	32 - 45	Stand-alone with slow music trigger
116 - 140	46 - 55	Stand-alone with medium music trigger
141 - 175	56 - 68	Stand-alone with fast music trigger
176 - 210	69 - 82	Stand-alone with random music trigger
211 - 255	83 - 100	Manual trigger area, crossover at 240 (94%)

6/7-CHANNEL DMX OPERATION

The 6 and 7 channel modes provide all functions listed in the DMX protocol on page 21.

Channel 1 controls the light intensity and the strobe rate. It also allows you to execute a random “stand-alone” program using automatic or music trigger, and to reset the fixture to its home position.

Channel 2 controls the rotation of the parabolic reflector. This channel has no effect if the stand-alone program is selected on channel 1.

Channel 3 controls the color/gobo wheel. This channel functions even if the stand-alone program is selected. When strobe is selected, the wheel alternates between the selected position and the one before it. To strobe between open and closed, select the open position.

Channel 4 controls the mirror drum’s swivel angle.

Channel 5 controls mirror drum rotation. Channels 4 and 5 have no effect if the stand-alone program is selected.

Channel 6 controls the drum’s swivel speed, allowing you to vary the speed with controllers without cross-fade times. If your controller has cross-faders and you use them, turn the speed function off by setting channel 6 to 0 percent. This channel has no effect if stand-alone is selected.

Channel 7 provides speed control of the effect wheel, allowing you to program slow transitions from one effect to another.

To set the 6/7-ch. DMX jumper

- 1 Disconnect the fixture from power.
- 2 Remove the effects section cover. It is secured by 5 Torx-20 screws: 3 on the side with print and 2 on the other side.
- 3 Locate PL 118 on the printed circuit board, next to DIP-switch pin 12.
- 4 Using a pair of tweezers or similar tool, place the jumper on 1 of the 2 pins, or remove it completely, for 6-channel DMX operation. Place the jumper on both pins to enable 7-channel DMX operation.
- 5 Replace the cover before applying power.

To replace the main fuse

- 1 Unplug the mains cable from the input socket. Pry open the fuse holder and remove the fuse.
- 2 Replace the fuse with one of the same type. The fuse rating is listed on serial number label.

TROUBLESHOOTING

10

Problem	Probable cause(s)	Remedy
Fixture is completely dead.	No power to fixture.	Check that power is switched on and cables are plugged in.
	Primary fuse blown.	Replace fuse.
	Secondary fuse blown.	Contact Martin technician for service.
Fixture resets correctly but does not respond to controller.	The DMX signal is not transmitted.	Connect controller. Inspect connections and cables. Correct poor connections. Repair or replace damaged cables.
	The DMX data signal is reversed.	Insert a phase-reversing cable in the link before the fixture.
	Incorrect address or other DIP-switch setting.	Check DIP-switch settings.
Intermittent flicker or strange behavior.	Data link not terminated.	Insert termination plug in output of the last fixture on the link.
	One of the fixtures is transmitting as a master or is defective.	Bypass one fixture at a time until normal operation is regained: unplug both connectors and connect them directly together. Have the defective fixture serviced by a qualified technician.
Effect fails to reset correctly.	The effect requires mechanical adjustment.	Contact Martin technician for service.
No light.	Lamp missing or blown	Disconnect fixture and replace lamp.
Lamp cuts out intermittently or burns out too quickly.	Extreme vibrations.	Relocate fixture away from speakers.
	The operating voltage does not match AC supply.	Contact Martin technician for service.
	Blocked air vent.	Increase clearance around fixture.
	Dust buildup inside fixture.	Contact Martin technician for professional cleaning.

DMX PROTOCOL

A

Channel	Value	Percent	Function	
1	0 - 4	0 - 1	Dimmer, Strobe, Reset	
	5 - 154	2 - 60	Light off	
	155 - 169	61 - 66	Dimmer, closed to open	
	170 - 229	67 - 89	Dimmer full open	
	230 - 239	90 - 93	Strobe, fast to slow	
	240 - 249	94 - 97	Stand-alone, music trigger	
	250 - 255	98 - 100	Stand-alone, auto trigger	
			Reset	
2	0 - 1	0 - 1	Parabolic Reflector	
	2 - 122	1 - 48	Stop	
	123 - 132	49 - 52	CCW rotation, slow to fast	
	133 - 253	52 - 99	Stop	
	254 - 255	99 - 100	CW rotation, fast to slow	
		Stop		
3	0 - 11	0 - 4	Color / Gobo Wheel	
	12 - 23	5 - 8	Open	
	24 - 35	9 - 13	Worms	
	36 - 47	14 - 18	Web	
	48 - 59	19 - 23	Petals	
	60 - 71	24 - 27	Spokes	
	72 - 83	28 - 32	Cone	
	84 - 95	33 - 37	Maze	
	96 - 107	38 - 41	Crater	
	108 - 119	42 - 46	Holes	
	120 - 131	47 - 51	Cross	
	132 - 143	52 - 55	Jagged Cross	
	144 - 155	56 - 60	Atomic	
	156 - 167	61 - 65	Dot Circle	
	168 - 179	66 - 70	Nordic	
	180 - 191	71 - 74	Aim	
	192 - 203	75 - 79	Pie	
	204 - 215	80 - 84	Tie	
	216 - 227	85 - 88	Nova	
	228 - 239	89 - 96	Triple Beam	
	240 - 255	97 - 100	Blackout	
			Random "stand-alone" position w/ music or auto trigger	
	4	0 - 255	0 - 100	Mirror Drum Swivel
				Left to right (127 = neutral)
	5	0 - 1	0 - 1	Mirror Drum Rotation
		2 - 122	1 - 48	Stop
		123 - 132	49 - 52	CW rotation, slow to fast
		133 - 253	52 - 99	Stop
		254 - 255	99 - 100	CCW rotation, fast to slow
			Stop	
	6	0 - 2	0 - 1	Mirror Swivel Speed
3 - 255		2 - 100	Tracking (speed function off)	
		Fast to slow		
7*	0 - 255	0 - 100	Color / Gobo Speed (*extended mode only)	
			Fast to slow	

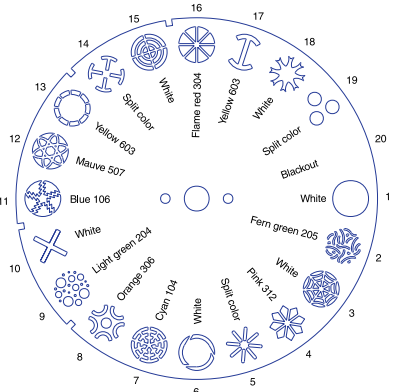

SPECIFICATIONS

B

PHYSICAL

- Size (L x W x H) 490 x 165 x 190 mm (19.3 x 6.5 x 7.5 in)
- Weight 8 kg (17.5 lbs)

THERMAL

- Maximum ambient temperature (T_a).....40° C (104° F)
- Maximum surface temperature60° C (140° F)

CONTROL AND PROGRAMMING

- Data pin-out..... 3-pin locking XLR, pin 1 shield, pin 2 cold (-), pin 3 hot (+)
- Control protocol USITT DMX-512 (1990)
- DMX channels 1/6

AC POWER

- Input 3-prong IEC male socket
- Maximum power and current..... 275 W, 1.2 A @ 230 V
- Primary fuse, EU version.....2.5 AT / 250 V, P/N 05020010
- Primary fuse, US version5.0 AT / 250 V, P/N 05020018
- Secondary fuse2.0 AT / 250 V, P/N 05020009

INSTALLATION

- Minimum distance to combustible materials 0.1 m (4 in)
- Minimum distance to illuminated surfaces 0.3 m (12 in)
- Minimum clearance around fan and air vents 0.1 m (4 in)

ACCESSORIES

- MC-1 controller, EU 90718000
- MC-1 controller, US..... 90718100
- Osram 24V/250W ELC 50 h halogen lamp..... 97000104
- Philips 24V/250W ELC 500 h halogen lamp..... 97000107
- G-clamp 91602003
- Half-coupler clamp 91602005

